

## DBC-1200S (line extender) smart RF amplifier one active output - optional two passive outputs

---

- DOCSIS 3.1 (1.2 GHz/204 MHz) ready
- Forward path gain up to 44 dB and return path gain up to 28 dB
- Full electronic smart control and setup via software tools
- Modular, field upgradeable, power-efficient design
- Remote diagnostic via DOCSIS transponder

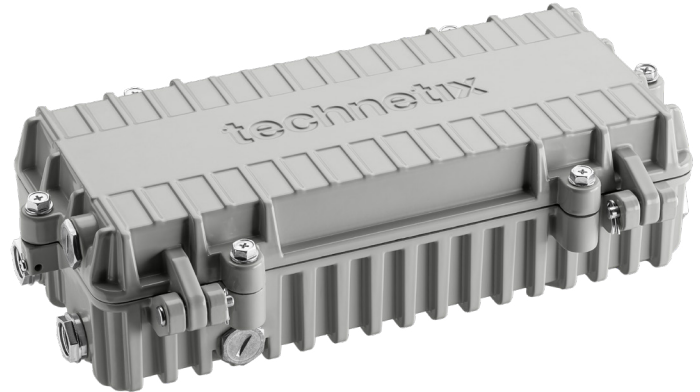

---

### DBx Open Access Platform

The Technetix DBx-1200 is a compact modular open access platform which supports both amplifier, node and Remote PHY/MAC-PHY configurations. Its modularity means that the platform can be field upgraded throughout its lifecycle and is not limited purely to higher diplex splits but can evolve with your network. Using CPD Safe™ technology means fewer reported faults, improved customer service and a reduction in truck rolls. The platform has an IP68 rating which enables deployments in challenging outdoor environments. The DBx platform has an unmatched Total Cost of Ownership (TCO) in the industry.

### DBC-1200S

The Technetix DBC-1200S amplifier is a line extender that has a single active output. It can be configured for use as a two output device (by placing an internal passive splitter or directional coupler). The DBC supports 1x1 applications with one active downstream (up to 44 dB gain) and one active upstream port (up to 28 dB gain), the exact performance and configuration depend on the modules that are equipped. The unit can be powered from any RF port and is suitable for aerial or underground application.

### Smart configuration

The controller module enables digital control of all settings using a USB port or an optional DOCSIS transponder for

remote control and monitoring. An ingress detection switch can be set remotely via an FSK protocol. With an integrated agile AGC/ALSC functionality it keeps the network stable during extreme temperature changes. Software tools used to set-up and control the platform are BLL (Windows), BLA (Android) and t-box which enables wireless access.

### Node transformation

An operational DBC-1200 amplifier can be converted to a 1x1 node in 10 minutes by placing a fiber tray and a fiber gland in the lid. Then swap the downstream module with an optical receiver and the upstream module with an optical transmitter. The laser wavelength can be any standard wavelength and includes the CWDM grid. The laser boards in the optical transmitter module can easily be swapped in the field.

### Green solution

The DBx family uses highly efficient power supplies to reduce power consumption while maintaining high reliability figures. Due to the modular approach newer technology can be introduced to the platform which further reduces power consumption. Our modules have a configurable low power mode for less demanding applications. As the platform can grow with your needs and modules are compatible across the platform, there is less waste when using the DBx portfolio.

# DBC-1200S (line extender) smart RF amplifier one active output - optional two passive outputs

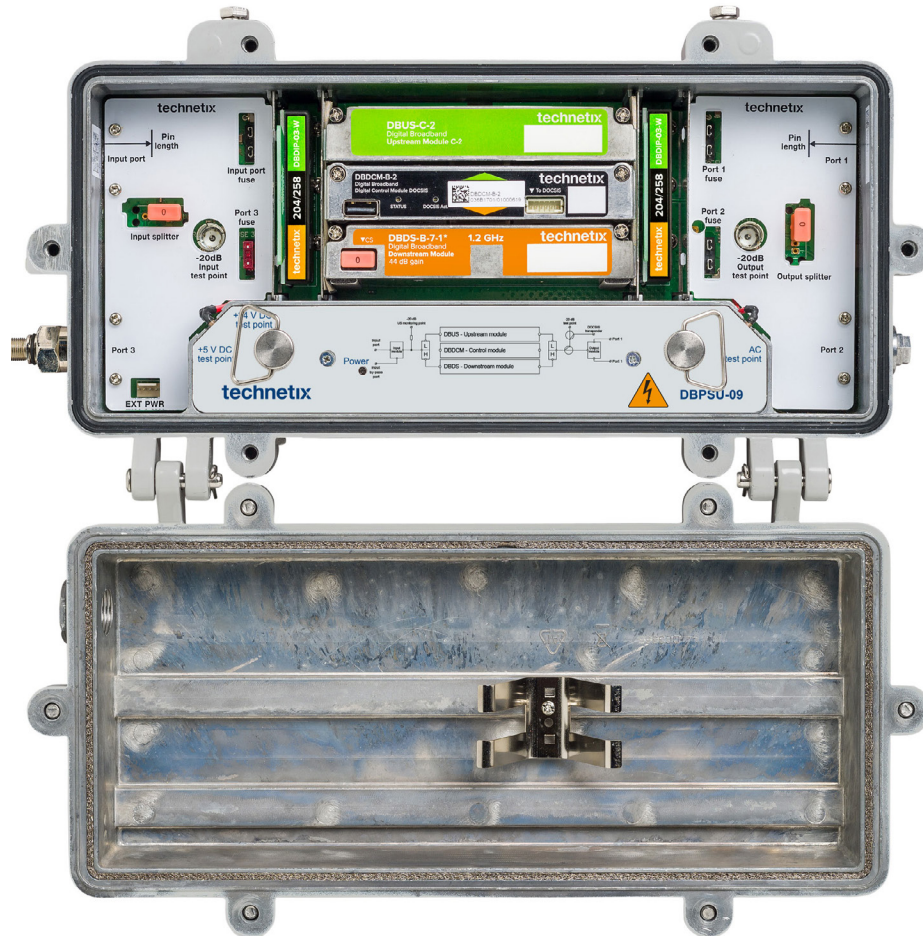

## Block diagram RF configuration

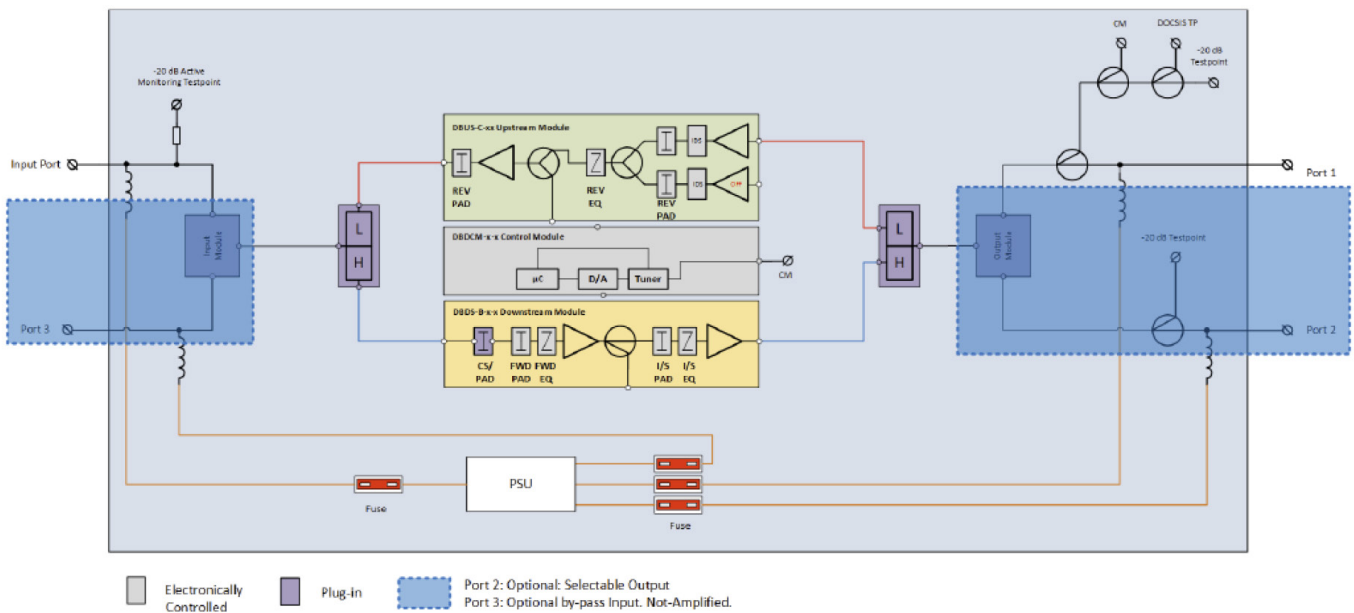

# DBC-1200S (line extender) smart RF amplifier one active output - optional two passive outputs

## DBC device and performance specifications

Specification	Forward path	Return path	Value
Pass band (dependent on diplex filter) <sup>(9)</sup>	54-1218	5-204	MHz
Active outputs	1	1	
Available outputs (with splitter or DC)	2	2	
Frequency response <sup>(1)</sup>	±0.75	±0.5	dB
Operational gain <sup>(7)</sup>	44	28	dB
Return loss <sup>(2)</sup>	18	16	dB
Noise figure (with zero dB attenuation)	8	6.5	dB
Operating output level <sup>(8)</sup>	>49 (109)		dBmV (dBµV)
Attenuator control (electronic) pre-stage <sup>(6)</sup>	0-20	0-20	dB
EQ control (electronic) pre-stage <sup>(6)</sup>	0-18		dB
Attenuator control (electronic) inter-stage <sup>(6)</sup>	0-15		dB
EQ control (electronic) inter-stage <sup>(6)</sup>	0-15	0-15	dB
Input monitoring point <sup>(5)</sup>	-20 ±1.5		dB
Output test-points	-20 ±1		dB
Reverse gain 25 dB NPR 5-65 MHz NPR 5-204 MHz		>50 dB: 24 dB dynamic range >50 dB: 21 dB dynamic range	
Reverse gain 28 dB NPR 5-65 MHz NPR 5-204 MHz		>50 dB: 20 dB dynamic range >50 dB: 16 dB dynamic range	
Ingress detection switches		0/6/40(off)	dB

General specifications	DBC-1200S	Units
Hum modulation <sup>(4)</sup>	-65 dBc at 15 A	
Class of enclosure	IP68 IEC 60529 2.1 at 1 - 2 metres underwater	
ESD	ANSI/SCTE 186	4 kV EN 61000-4-2:2008
Surge protection	ANSI/SCTE 81; C62.41 CAT. C3	6 kV IEEE C62.41 CAT C3
EMC	FCC CFR 47 part 15:2013	EN 50083-2:2012
Safety	ANSI/UL-60950-1	EN 60728-11:2011
Test points	F-Female	
Operating voltage	30-65 VAC sine wave, 35-90 VAC quasi-square wave	
Power consumption <sup>(3)</sup>	19	W
AC bypass and capacity & input	15	A
Operating temperature range	-40 to +65	°C
	-40 to +149	°F
Housing dimensions	7.75 x 13.97 x 3.7	inch
	197 x 355 x 94	mm
Coaxial connections	PG11 or 5/8"	
Housing finish	Painted conductive chromate finish	
Impedance	75	Ω
Equipment approval	CE/RoHS/FCC	

# DBC-1200S (line extender) smart RF amplifier one active output - optional two passive outputs

## Ordering information

Category	Order number	Type	Description
Upstream RF modules	19008429	DBUS-C-1	Main module: 204 MHz upstream amplifier 25 dB gain and IDS
	19013960	DBUS-C-2	Main module: 204 MHz upstream amplifier 28 dB gain and IDS
	19008430	DBUS-D-1	Bridger module: 204 MHz upstream amplifier 25 dB gain and IDS
Downstream RF modules	19009835	DBDS-B-7-1	Main: 1.2 GHz downstream amplifier 44 dB - I2 C - 52 dBmV output
	19009834	DBDS-F-5-1	Bridger: 1.2 GHz downstream amplifier 44 dB - I2 C - 52 dBmV output
Digital control and monitoring	19005026	DBDCM-A-1	Control module: AGC/ALSC, FSK, USB-A
	19005027	DBDCM-B-2	Control module: AGC/ALSC, DOCSIS transponder compatible, USB-A
	19005029	DBDDM-A-1	DOCSIS 3.0 transponder, requires DBDCM-B-2
	19010542	DBDDM-B-1	EuroDOCSIS 3.0 transponder, requires DBDCM-B-2
Diplex filters	19008513	DBDIP-01(-W)	65/85 MHz diplexer
	19008514	DBDIP-02(-W)	85/105 MHz diplexer
	19008515	DBDIP-03(-W)	204/258 MHz diplexer
	19008541	DBDIP-04- I(-W)	42/54 MHz diplexer - Input
	19008540	DBDIP-04-O(-W)	42/54 MHz diplexer - Output
	19009966	DBDIP-05(-W)	85/102 MHz diplexer
	19012966	DBDIP-05-5	85/102 MHz diplexer with 5 dB insertion loss in downstream
	19012967	DBDIP-05-5-W	85/102 MHz wide diplexer with 5 dB insertion loss in downstream
Power supplies	19013941	DBPSU-09	35 W power supply 35-65VAC Sine Wave, 42-90 VAC Square Wave
Termination module	19008482	DBTM-T-1	75 $\Omega$ terminating module

## Remarks:

1. Aligned with 20 dB coaxial cable.
2. At 40 MHz, deduct 1.5 dB per octave (never worse than 12 dB).
3. Typical, without DOCSIS transponder @50 VAC. Detailed information is shown on the powering data table.
4. Max value up to 1 GHz. From 1 GHz to 1.2 GHz max value -60 dB.
5. Measured with 22 dB ATT JXP in DS 1 module.
6. Max EQ value in inter-stage. There is a 18 dB EQ available in pre-stage controlled electronically. Reference output tilt for:
  - a. 1218-54 MHz is 18 dB
  - b. 1218-204 MHz is 15 dB
7. Forward gain measured with 0 dB input EQ and 0 dB input attenuator. Thermal back-off includes 1 dB. Additional back-off is available and is configured via software tools.
8. All digital loading. 49 dBmV QAM at 1218 MHz, 18 dB tilt to 54 MHz. Operational minimum input level at 1218 MHz is 6 dBmV/channel.
9. Available diplex filters: 42/54 MHz, 68/85 MHz, 85/102 MHz, 85/105 MHz, 204/258 MHz.

# DBC-1200S (line extender) smart RF amplifier one active output - optional two passive outputs

## Powering data for DBC-1200S line extender single active output

Parameter	AC Voltage - Frequency 47 - 63 Hz										
V	42	45	50	55	60	65	70	75	80	85	90
A	0.445	0.413	0.370	0.335	0.307	0.283	0.264	0.249	0.238	0.224	0.216
W	18.70	18.60	18.50	18.40	18.40	18.40	18.50	18.70	19.00	19.00	19.40

## NPR of DBC-1200S line extender for different band splits

