

Installation taps and splitters

1.8 GHz Core Series Topless 4-way Taps

technetix

- Frequency range 12 - 1825 MHz
- Best in class RF performance
- Modem Safe surge protection on all ports
- CPD Safe corrosion protection using White Bronze plating
- F-connectors provide superb retention force

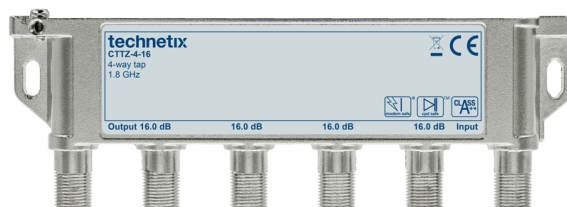

Overview

The Core series is our next generation of installation passives which excel in both electrical and mechanical performance. Though designed for indoor use, they are also specified for use in street-side plant. The products are easy to install with a compact housing, specifically sized to make replacement and upgrade installation simple.

Intermodulation performance, which is an important factor in high-level return path signals, has been greatly improved through a newly developed ferrites and specially designed circuits. The intermodulation performance remains very high even after being exposed to electrical surges from the network on all ports.

The screening effectiveness meets the Class A++ requirements defined in EN 50083-2:2012 across the whole frequency range from 12 to 1825 MHz. To provide maximum protection against interference from 4G/5G signals.

Technetix Modem Safe®

Technetix Modem Safe® is a highly effective surge protection solution for sensitive network and in-home CPE. This technology is based on passive circuits and is not reliant on discharge tubes, therefore extending the lifespan of the solution.

- Blocks high and low voltage pulses and unwanted DC voltages
- Prevents internal ferrites within the product from becoming magnetised (avoiding deterioration in the performance of CPE)
- Drives fewer reported faults, improving customer service and reducing truck rolls

Technetix CPD Safe™

Common Path Distortion (CPD) is well known for producing signal interference in the network. It is caused by electrolytic corrosion or the oxidation of dissimilar metals when in close contact. Technetix CPD Safe™ technology protects against CPD.

- Removes a primary cause of CPD
- Reduces signal interference in the network
- Drives fewer reported faults, improving customer service and reducing truck rolls

Installation taps and splitters

1.8 GHz Core Series Topless 4-way Taps



Insertion loss (In to out)

	CTTZ-4-10T	CTTZ-4-12	CTTZ-4-12T	CTTZ-4-16	CTTZ-4-20	CTTZ-4-24	CTTZ-4-28	
Frequency	Max	Max	Max	Max	Max	Max	Max	Notes
12	n/a	4.2	n/a	2.6	2.0	2.0	2.0	1, 2, 3
200	n/a	4.6	n/a	2.9	2.3	2.3	2.3	1, 2, 3
750	n/a	5.7	n/a	3.9	3.3	3.3	3.3	1, 2, 3
860	n/a	5.9	n/a	4.0	3.4	3.4	3.4	1, 2, 3
1006	n/a	6.2	n/a	4.34	3.7	3.7	3.7	1, 2, 3
1218	n/a	6.7	n/a	4.7	4.1	4.1	4.1	1, 2, 3
1825	n/a	7.9	n/a	5.7	5.1	5.1	5.1	1, 2, 3

Insertion loss (In to tap)

	CTTZ-4-10T		CTTZ-4-12		CTTZ-4-12T		CTTZ-4-16		CTTZ-4-20		CTTZ-4-24		CTTZ-4-28		
Frequency	Typ	Max	Typ	Max	Typ	Max	Typ	Max	Typ	Max	Typ	Max	Typ	Max	Notes
12	10.0	11.5	12.0	13.5	12.0	13.5	16.0	17.5	20.0	21.5	24.0	25.5	28.0	29.5	1, 2, 3
1825	11.0	12.8	13.0	14.8	13.0	14.8	17.0	18.8	21.0	22.8	25.0	26.8	28.5	30.3	1, 2, 3

Isolation (Out to tap)

	CTTZ-4-10T	CTTZ-4-12	CTTZ-4-12T	CTTZ-4-16	CTTZ-4-20	CTTZ-4-24	CTTZ-4-28	
Frequency	Min	Min	Min	Min	Min	Min	Min	Notes
12	n/a	25	n/a	26	34	35	36	1, 2, 3
47	n/a	26	n/a	27	35	36	37	1, 2, 3
1218	n/a	20	n/a	20	20	24	28	1, 2, 3
1825	n/a	20	n/a	20	20	24	26	1, 2, 3

Installation taps and splitters

1.8 GHz Core Series Topless 4-way Taps



Isolation (Tap to tap)

	CTTZ-4-10T	CTTZ-4-12	CTTZ-4-12T	CTTZ-4-16	CTTZ-4-20	CTTZ-4-24	CTTZ-4-28	
Frequency	Min	Min	Min	Min	Min	Min	Min	Notes
12	36	38	38	38	38	38	40	1, 2, 3
47	36	38	38	38	38	38	40	1, 2, 3
1218	27	27	27	28	30	31	32	1, 2, 3
1825	24	24	24	25	27	28	28	1, 2, 3

Return loss

	CTTZ-4-10T	CTTZ-4-12	CTTZ-4-12T	CTTZ-4-16	CTTZ-4-20	CTTZ-4-24	CTTZ-4-28	
Frequency	Min	Min	Min	Min	Min	Min	Min	Notes
12	14	14	14	14	14	14	14	1, 2, 3
15	18	18	18	18	18	18	18	1, 2, 3
30	18	18	18	18	18	18	18	1, 2, 3
100	18	18	18	18	18	18	18	1, 2, 3
200	17	17	17	17	17	17	17	1, 2, 3
400	16	16	16	16	16	16	16	1, 2, 3
800	16	16	16	16	16	16	16	1, 2, 3
1218	16	16	16	16	16	16	16	1, 2, 3
1825	14	14	14	14	14	14	14	1, 2, 3

Installation taps and splitters

1.8 GHz Core Series Topless 4-way Taps



Electrical specifications

Parameter		Frequency	Min	Typ	Max	Units	Notes
Frequency			12		1825	MHz	
Impedance				75		Ohm	
Surge	All ports				1	kV	7
Intermodulation p+q	Before surge				122	dBc	4
	After 25V surge				115	dBc	5
	After 1kV surge				115	dBc	6
Screening class A++		12-30	100/2.5			dB / mΩ/m	8
		30-1000	105			dB	8
		1000-1825	95			dB	8

Environmental specifications

Parameter		Frequency	Min	Typ	Units	Details	Notes
Temperature		Operational	-15	45	°C		2
		Operational extended	-40	85	°C		3
		Storage	-40	70	°C		
	Temperature cycle					EN 60068-2-14	

Parameter	Standard	Severity
IP rating	EN 60529 1992	IP68
Drop test	EN 60068-2-31:2008	Rough handling shocks (9)
Dry heat	EN 60068-2-2 2007	85oC, 72 hrs
Temp Cycling with Humidity	EN 60068-2-30:2005	55 oC, 6 cycles, 95% RH
Vibration	EN 60068-2-6	Amplitude of 0.15mm or 20m/s ² , the frequency varying exponentially with time from 10 Hz and 150 Hz and back. One cycle taking 5 mins.
Salt Fog	EN 60068-2-52 2018	Test method 4 (14 Days)

Installation taps and splitters

1.8 GHz Core Series Topless 4-way Taps

technetix

Mechanical specifications

Parameter		Details
Connectors	F-connectors	EN 61169-24
	Conductor size acceptance	0.64 - 1.30 mm - enhancement on EN 61169-24
	Withdrawal force	115 grams - cycle 0.7mm, 1.2mm, 0.7mm 1.2mm, 0.7mm
Conductors	Inner contact	BeCu silver plated
Housing material	Body	Die-cast zinc alloy, white bronze plated
	Lid	Mild steel

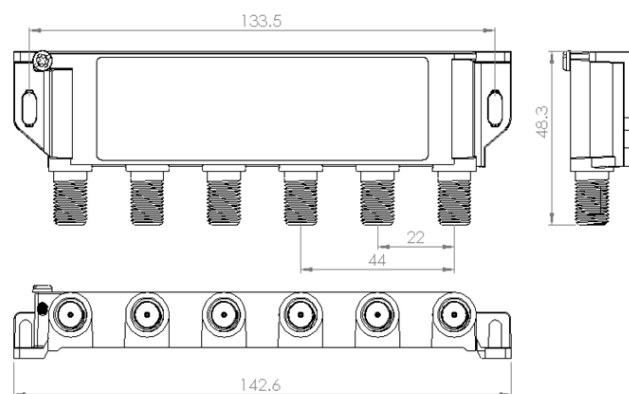

Notes

1	Point to point linear limit line
2	Deviation over operation temperature range: +/-0.5 dB insertion loss. +2 dB isolation and return loss
3	Deviation over extended operational temperature: +/-1 dB insertion loss. +5 dB isolation and return loss
4	Two carriers (60 & 65 MHz), out to out, @ 120 dBuV, fully demagnetized
5	Two carriers (60 & 65 MHz), out to out, out to tap (worse case), @ 120 dBuV, after 10 pulses (25V/1.2uS rise time / 500uS duration) at all ports.
6	Two carriers (60 & 65 MHz), out to out, out to tap (worst case), @ 120 dBuV, after 1x positive and 1x negative pulses (1kV/1.2uS rise time / 50uS fall time) at all ports.
7	Surge pulse 1kV/1.2uS rise time / 50uS fall time (IEC61000-4-5:1995) 2 Ω source impedance (1x positive and 1x negative)
8	IEC 62153-7 § 5.5, IEC 60728-2 and EN-50083 (transfer impedance method, absorbing clamp)

Ordering information

Item number	Item code	Description
19014149	CTTZ-4-12	CORE 4-WAY TOPLESS TAP 12DB 1.8GHZ
19014150	CTTZ-4-16	CORE 4-WAY TOPLESS TAP 16DB 1.8GHZ
19014151	CTTZ-4-20	CORE 4-WAY TOPLESS TAP 20DB 1.8GHZ
19014152	CTTZ-4-24	CORE 4-WAY TOPLESS TAP 24DB 1.8GHZ
19014153	CTTZ-4-28	CORE 4-WAY TOPLESS TAP 28DB 1.8GHZ
19014154	CTTZ-4-10T	CORE 4-WAY TOPLESS TAP 10DB 1.8GHZ TERMINATED
19014155	CTTZ-4-12T	CORE 4-WAY TOPLESS TAP 12DB 1.8GHZ TERMINATED

Technetix Group Limited
March 2023 - V1

e: sales@technetix.com w: technetix.com

© Copyright 2023 Technetix Group Limited. All rights reserved. This document is for information only. Features and specifications are subject to change without notice. Technetix, the Technetix logo and certain other marks and logos are trade marks or registered trade marks of Technetix Group Limited in the UK and certain other countries. Other brand and company names are trade marks of their respective owners. Technetix protects its technology and designs by registering patents, trade marks and designs in Europe and certain other countries.