

# Installation taps and splitters

## 1.8 GHz Core Series Topless 1-way Taps

technetix

- Frequency range 12 - 1825 MHz
- Best in class RF performance
- Modem Safe surge protection on all ports preventing intermodulation
- CPD Safe corrosion protection using White Bronze plating
- F-connectors provide superb retention force

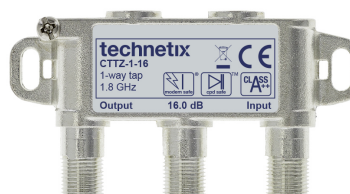

### Overview

The Core series is our next generation of installation passives which excel in both electrical and mechanical performance. Though designed for indoor use, they are also specified for use in street-side plant. The products are easy to install with a compact housing, specifically sized to make replacement and upgrade installation simple.

Intermodulation performance, which is an important factor in high-level return path signals, has been greatly improved through a newly developed ferrites and specially designed circuits. The intermodulation performance remains very high even after being exposed to electrical surges from the network on all ports.

The screening effectiveness meets the Class A++ requirements defined in EN 50083-2:2012 across the whole frequency range from 12 to 1825 MHz. To provide maximum protection against interference from 4G/5G signals.

### Technetix Modem Safe®

Technetix Modem Safe® is a highly effective surge protection solution for sensitive network and in-home CPE. This technology is based on passive circuits and is not reliant on discharge tubes, therefore extending the lifespan of the solution.

- Blocks high and low voltage pulses and unwanted DC voltages
- Prevents internal ferrites within the product from becoming magnetised (avoiding deterioration in the performance of CPE)
- Drives fewer reported faults, improving customer service and reducing truck rolls

### Technetix CPD Safe™

Common Path Distortion (CPD) is well known for producing signal interference in the network. It is caused by electrolytic corrosion or the oxidation of dissimilar metals when in close contact. Technetix CPD Safe™ technology protects against CPD.

- Removes a primary cause of CPD
- Reduces signal interference in the network
- Drives fewer reported faults, improving customer service and reducing truck rolls

# Installation taps and splitters

## 1.8 GHz Core Series Topless 1-way Taps



### Insertion loss (In to out)

	CTTZ-1-6	CTTZ-1-8	CTTZ-1-10	CTTZ-1-12	CTTZ-1-16	CTTZ-1-20	CTTZ-1-24	CTTZ-1-30	
Frequency	Max	Max	Max	Max	Max	Max	Max	Max	Notes
12	2.8	2.2	1.7	1.7	1.3	1.3	1.3	1.3	1, 2, 3
200	3.0	2.4	1.9	1.8	1.4	1.4	1.4	1.4	1, 2, 3
750	3.4	2.9	2.3	2.1	1.7	1.7	1.7	1.7	1, 2, 3
860	3.5	2.9	2.4	2.2	1.7	1.7	1.7	1.7	1, 2, 3
1006	3.6	3.1	2.5	2.2	1.8	1.8	1.8	1.8	1, 2, 3
1218	3.8	3.3	2.7	2.4	1.9	1.9	1.9	1.9	1, 2, 3
1825	4.0	3.8	3.2	2.7	2.2	2.2	2.2	2.2	1, 2, 3

### Insertion loss (In to tap)

	CTTZ-1-6		CTTZ-1-8		CTTZ-1-10		CTTZ-1-12		CTTZ-1-16		CTTZ-1-20		CTTZ-1-24		CTTZ-1-30		
Frequency	Typ	Max	Typ	Max	Typ	Max	Typ	Max	Typ	Max	Typ	Max	Typ	Max	Typ	Max	Notes
12	6.0	7.5	8.5	10	10	11.5	12.5	14	16	17.5	20	21.5	24	25.5	30	31.5	1, 2, 3
1825	6.0	7.5	8.5	10	10	11.5	12.5	14	16	17.5	20	21.5	24	25.5	30	31.5	1, 2, 3

### Isolation (Out to tap)

	CTTZ-1-6	CTTZ-1-8	CTTZ-1-10	CTTZ-1-12	CTTZ-1-16	CTTZ-1-20	CTTZ-1-24	CTTZ-1-30	
Frequency	Min	Min	Min	Min	Min	Min	Min	Min	Notes
12	20	26	27	29	35	36	41	44	1, 2, 3
47	25	26	27	29	35	36	41	44	1, 2, 3
1218	20	20	20	20	20	24	27	30	1, 2, 3
1825	18	20	20	20	20	24	27	30	1, 2, 3

### Return loss

# Installation taps and splitters

## 1.8 GHz Core Series Topless 1-way Taps



	CTTZ-1-6	CTTZ-1-8	CTTZ-1-10	CTTZ-1-12	CTTZ-1-16	CTTZ-1-20	CTTZ-1-24	CTTZ-1-30	
Frequency	Min	Min	Min	Min	Min	Min	Min	Min	Notes
12	16	16	16	16	16	16	16	16	1, 2, 3
15	16	18	18	18	18	18	18	18	1, 2, 3
30	16	18	18	18	18	18	18	18	1, 2, 3
100	16	18	18	18	18	18	18	18	1, 2, 3
200	16	17	17	17	17	17	17	17	1, 2, 3
400	16	16	16	16	16	16	16	16	1, 2, 3
800	16	16	16	16	16	16	16	16	1, 2, 3
1218	16	16	16	16	16	16	16	16	1, 2, 3
1825	16	16	16	16	16	16	16	16	1, 2, 3

### Electrical specifications

Parameter		Frequency	Min	Typ	Max	Units	Notes
Frequency			12		1825	dB	
Impedance				75		Ohm	
Surge	All ports				1	kV	7
Intermodulation p+q	Before surge				122	dBc	4
	After 25V surge				115	dBc	5
	After 1kV surge				115	dBc	6
Screening class A++		12-30	100 / 2.5			dB / mΩ/m	8
		30-1000	105			dB	8
		1000-1825	95			dB	8

### Environmental specifications

Parameter		Frequency	Min	Max	Units	Details	Notes
Temperature		Operational	-15	45	°C		2
		Operational Extended	-40	85	°C		3
		Storage	-40	70	°C		
	Temperature Cycle					EN 60068-2-14	

# Installation taps and splitters

## 1.8 GHz Core Series Topless 1-way Taps



Parameter	Standard	Severity
IP rating	EN 60529 1992	IP68
Drop test	EN 60068-2-31:2008	Rough handling shocks (9)
Dry heat	EN 60068-2-2 2007	85oC, 72 hrs
Temp Cycling with Humidity	EN 60068-2-30:2005	55 oC, 6 cycles, 95% RH
Vibration	EN 60068-2-6	Amplitude of 0.15mm or 20m/s <sup>2</sup> , the frequency varying exponentially with time from 10 Hz and 150Hz and back. One cycle taking 5 mins.
Salt Fog	EN 60068-2-52 2018	Test Method 4 (14 Days)

### Mechanical specifications

Parameter	Frequency	Details
Connectors	F-Connectors	EN 61169-24
	Conductor size acceptance	0.64 - 1.30 mm
	Withdrawal force	115 grams
Conductors	Inner contact	BeCu Silver Plated
Housing material	Body	Die-Cast Zinc alloy, White Bronze plated
	Lid	Mild Steel

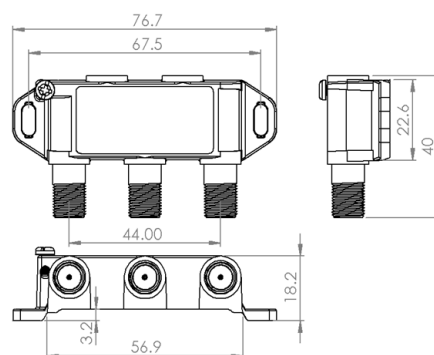

### Notes

- Point to point linear limit line
- Deviation over operation temperature range: +/-0.5dB insertion loss. +2dB Isolation and return loss
- Deviation over extended operational temperature: +/-1dB insertion loss. +5dB Isolation and return loss
- Two carriers (60 & 65MHz), Out to Out, @ 120dBuV, Fully Demagnetized
- Two carriers (60 & 65MHz), Out to Out, Out to Tap (worse case), @ 120dBuV, after 10 pulses (25V/1.2uS rise time / 500uS duration) at All ports.
- Two carriers (60 & 65MHz), Out to Out, Out to Tap (worse case), @ 120dBuV, after 1x positive and 1x negative pulses (1kV/1.2uS rise time / 50uS fall time) at All Ports.
- Surge pulse 1kV/1.2uS rise time / 50uS fall time (IEC61000-4-5:1995) 2 Ω source impedance (1x positive and 1x negative)
- IEC 62153-7 § 5.5, IEC 60728-2 and EN-50083 (Transfer impedance method, Absorbing Clamp)
- 0.5dB degradation in insertion loss and 3 dB degradation in return loss and isolation permissible over temperature range

# Installation taps and splitters

## 1.8 GHz Core Series Topless 1-way Taps



---

### Ordering information

Item number	Item code	Description
19014132	CTTZ-1-6	CORE 1-WAY TOPLESS TAP 6DB 1.8GHZ
19014133	CTTZ-1-8	CORE 1-WAY TOPLESS TAP 8DB 1.8GHZ
19014134	CTTZ-1-10	CORE 1-WAY TOPLESS TAP 10DB 1.8GHZ
19014135	CTTZ-1-12	CORE 1-WAY TOPLESS TAP 12DB 1.8GHZ
19014136	CTTZ-1-16	CORE 1-WAY TOPLESS TAP 16DB 1.8GHZ
19014137	CTTZ-1-20	CORE 1-WAY TOPLESS TAP 20DB 1.8GHZ
19014138	CTTZ-1-24	CORE 1-WAY TOPLESS TAP 24DB 1.8GHZ
19014139	CTTZ-1-30	CORE 1-WAY TOPLESS TAP 30DB 1.8GHZ