

technetix



OTTZ

1.8 GHz traditional outdoor multitaps

User manual

technetix.com
+1 (720) 931-6480
info-usa@technetix.com

Contents

Tools list		3
Overview		3
Step 1	Connector positions	4
Step 2	Installing the connectors	5
Step 3	Signal conditioning	6
Step 4	Tightening sequence of faceplate bolts	6
Step 5	Installing drop cable on faceplate	7
Step 6	Strand mount mechanism	7
Ordering information		8

Tool list

The following tools and supplies are required when installing an OTTZ outdoor tap:

- 3/8" (10 mm) nut driver for lid bolts
- 0.078" (2 mm) diameter Phillips head screwdriver for vertical installation
- Torque limiting spanner (wrench) tool 30 in/lbs (3.5 N-m) for F-connectors
- Torque limiting spanner (wrench) tool 40 in/lbs (4.5 N-m) for KS 5/8 connectors

Overview

To upgrade the outdoor access network to DOCSIS 4.0, the products need to support an extended frequency band to 1.8 GHz. The OTTZ range has been developed to meet the needs of the American market following SCTE guidelines for 1.8 GHz hardline multitaps.

The no-screw in/out connector interface has been greatly improved to meet the high RF performance and low maintenance needs of DOCSIS 4.0 deployments. The connectors, which, by default, are horizontally positioned, can easily be turned into the bottom position for pedestal installation when both cables come directly from the ground.

The tap supports signal conditioning plugins like cable simulators and cable equalizers. The 3 GHz housings have a bypass switch installed to ensure RF and AC pass through while the faceplate is being removed.

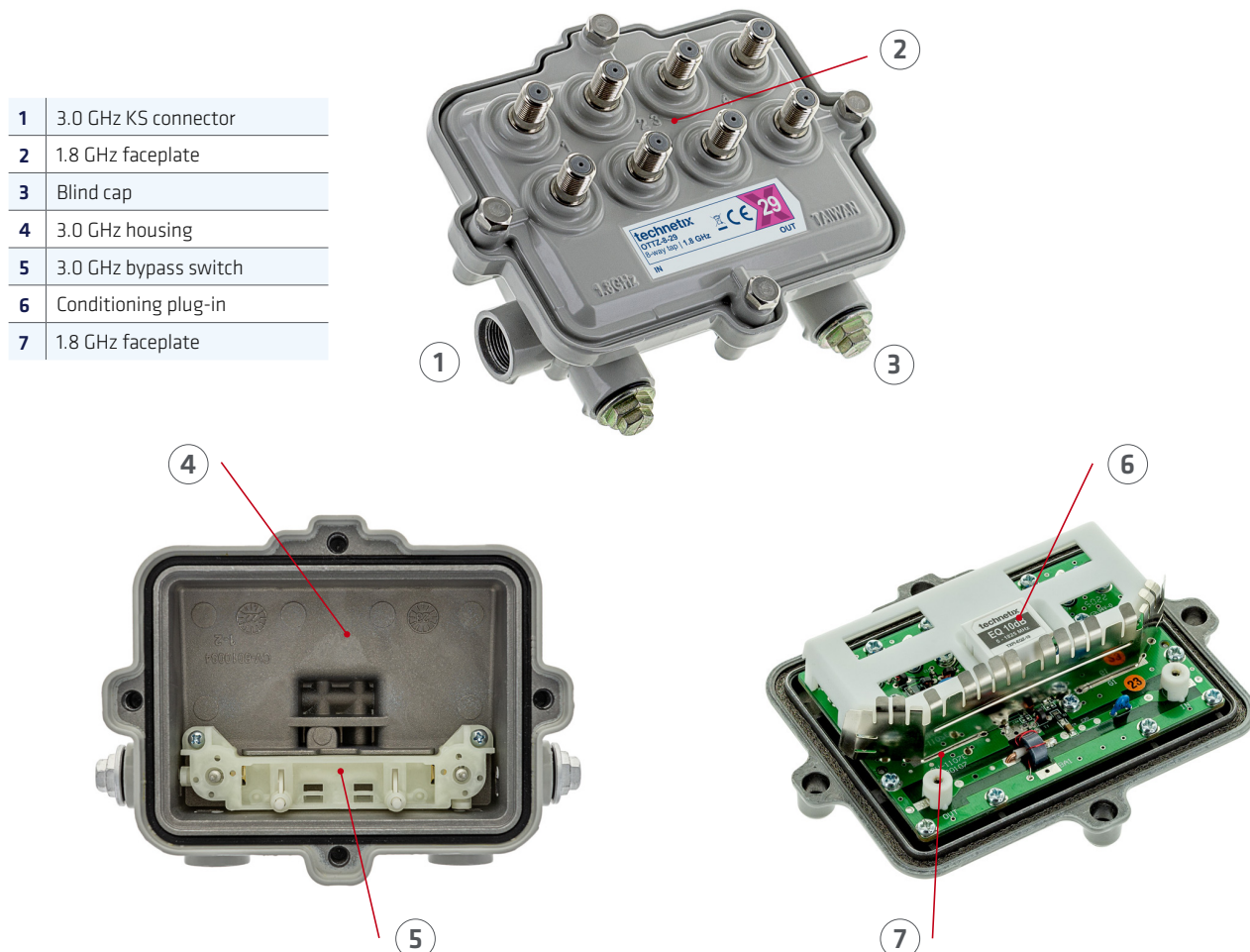

Step 1_Connector positions

Determine whether your cables will need to be fitted in a horizontal position (*Fig. 1*) or in a vertical position (*Fig. 2*) or a combination of the two positions.



Fig. 1

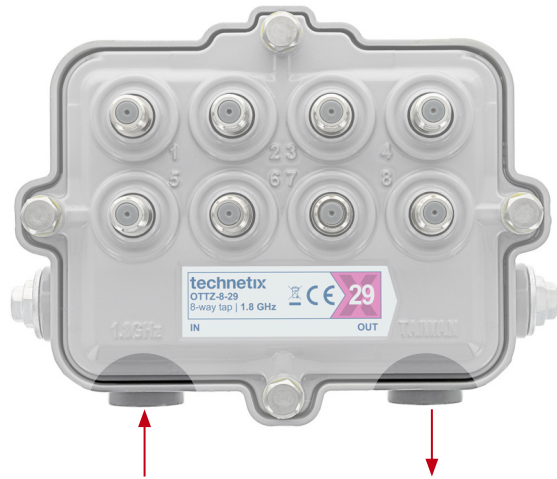

Fig. 2

For a horizontal orientation (*Fig. 1*), the in/out connectors are already in the correct position.

For a vertical orientation (*Fig. 2*), the in/out connectors need to be re-positioned for installation. This can be done from inside the tap, as shown in *Fig. 3*, or from outside the tap with careful handling of a small screwdriver (2 mm / 0.08 inch diameter), as shown in *Fig. 4*. When the connector is fully in the correct position, you will feel it snap and hold in position.

After changing the orientation, take care to re-fit the blind caps with at least 40 in/lbs torque to ensure a watertight installation.



Fig. 3

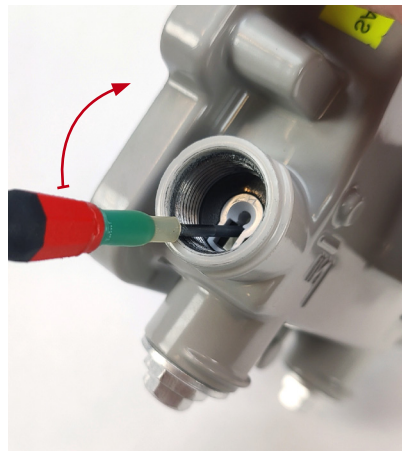
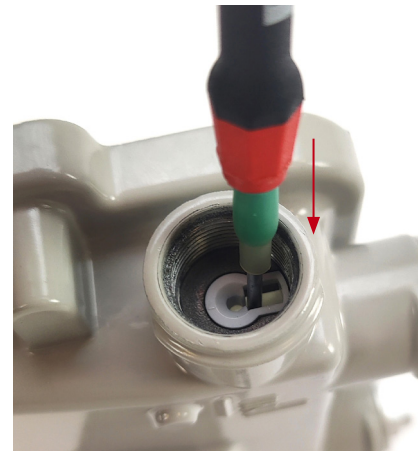

Fig. 4



Step 2_Installing the connectors

The housing is fitted with a seizureless 5/8 female connector designed to fit a standard KS 5/8 male connector without the need to secure the pin with a screw contact (unlike legacy multitaps).

1. Cut the 5/8 pin to a length of 1.28 inch (32.6 mm) with a tolerance of 0.031 inch (+/- 0.8 mm).
A cutting guide is marked on the back of the housing, as shown in *Fig. 5*.



IMPORTANT: The total pin length = pin length and connector thread length (*Fig. 5*).

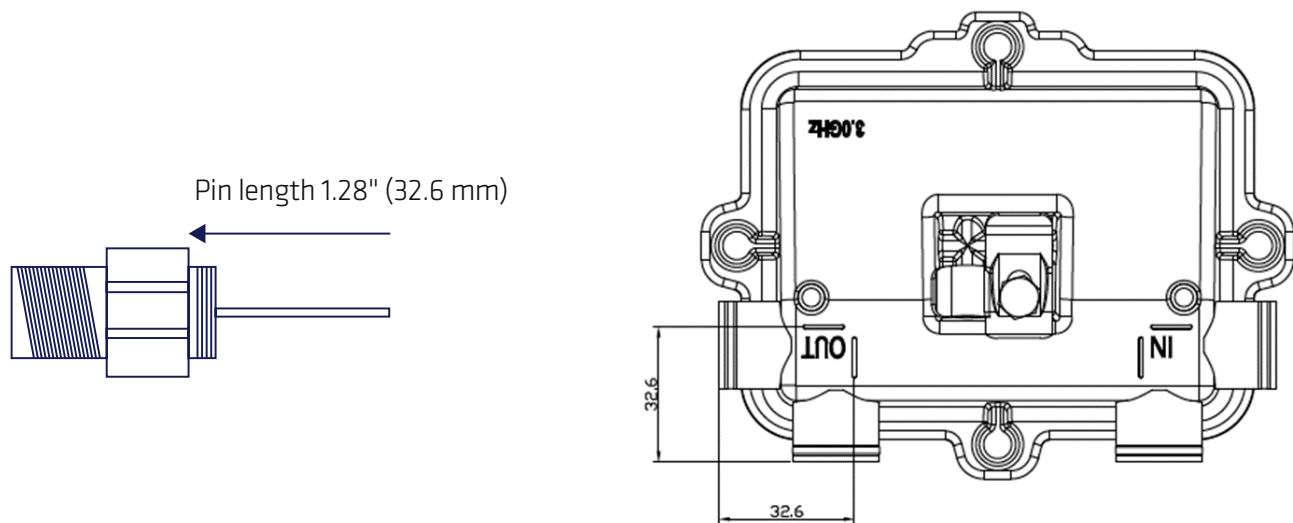

Fig. 5

2. The OTTZ 5/8 female connector takes pins with a diameter of 0.065 inch - 0.075 inch (1.65 - 1.91 mm).
3. Torque the KS connectors to 40 in/lbs (4.5 N-m).

Step 3_Signal conditioning

Signal conditioning is used in some networks to give a specific amount of tilt to the tap ports, enabling them to reach homes with a flat signal. In the OTTZ platform, the signal conditioning plug-ins (Fig. 5) can be installed in the faceplate, which are all delivered with a 0 dB jumper. When installing a cable equalizer or cable simulator, the 0 dB jumper in the faceplate will be replaced by the signal conditioning plug-in.

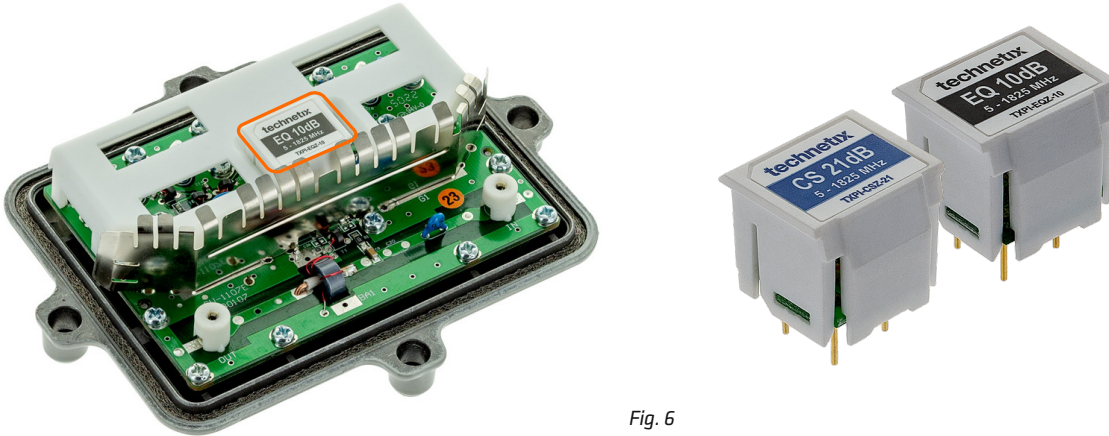

Fig. 6

Step 4_Tightening sequence of faceplate bolts

Fully tighten to 30 in/lbs (3.5 N-m) in the following sequence:

- ① Top bolt
- ② Bottom bolt
- ③ Left hand bolt
- ④ Right hand bolt



Step 5_Installing drop cable on faceplate

Fix the F-male connector to the drop cables while connecting to customer premises at the front F-female ports of the multitap, then tighten the connectors to 30 in/lbs (3.5 N-m) torque. Make sure all F-ports that are not in use are terminated with a 75 Ohm terminator also to 30 in/lbs (3.5 N-m) torque.



Step 6_Strand mount mechanism

Undo the bolt to secure the stand cable. Tighten the bolt to 30 in/lbs (3.5 N-m) torque.

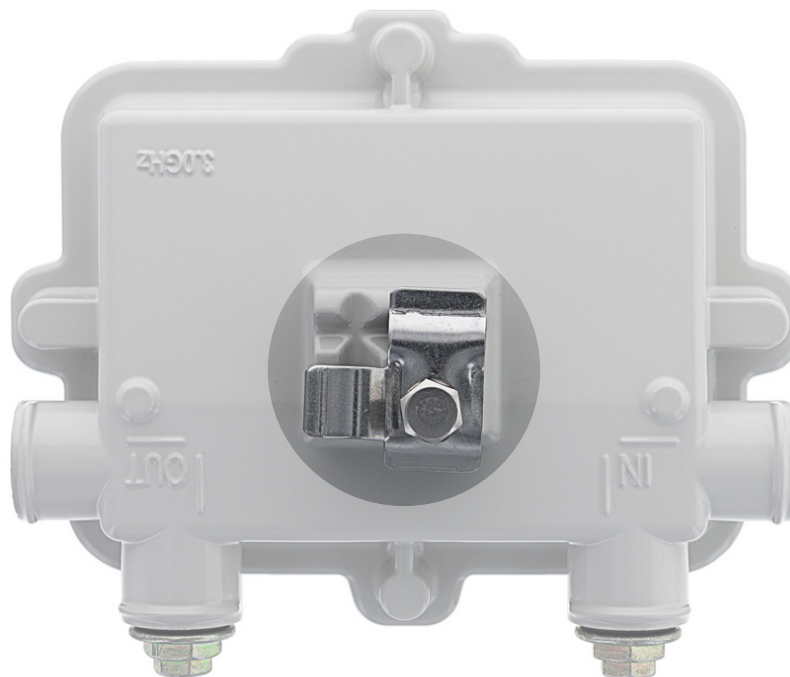

Order Information

Full taps

Item number	Item code	Description
19014593	OTTZ-2-4T	OUTDOOR TAP TECHNETIX WIDE 2-WAY 4 dB 1.8 GHz TERM
19014594	OTTZ-2-8	OUTDOOR TAP TECHNETIX WIDE 2-WAY 8 dB 1.8 GHz
19014595	OTTZ-2-11	OUTDOOR TAP TECHNETIX WIDE 2-WAY 11 dB 1.8 GHz
19014596	OTTZ-2-14	OUTDOOR TAP TECHNETIX WIDE 2-WAY 14 dB 1.8 GHz
19014597	OTTZ-2-17	OUTDOOR TAP TECHNETIX WIDE 2-WAY 17 dB 1.8 GHz
19014598	OTTZ-2-20	OUTDOOR TAP TECHNETIX WIDE 2-WAY 20 dB 1.8 GHz
19014599	OTTZ-2-23	OUTDOOR TAP TECHNETIX WIDE 2-WAY 23 dB 1.8 GHz
19014600	OTTZ-2-26	OUTDOOR TAP TECHNETIX WIDE 2-WAY 26 dB 1.8 GHz
19014601	OTTZ-2-29	OUTDOOR TAP TECHNETIX WIDE 2-WAY 29 dB 1.8 GHz
19014602	OTTZ-4-8T	OUTDOOR TAP TECHNETIX WIDE 4-WAY 8 dB 1.8 GHz TERM
19014603	OTTZ-4-11	OUTDOOR TAP TECHNETIX WIDE 4-WAY 11 dB 1.8 GHz
19014604	OTTZ-4-14	OUTDOOR TAP TECHNETIX WIDE 4-WAY 14 dB 1.8 GHz
19014605	OTTZ-4-17	OUTDOOR TAP TECHNETIX WIDE 4 WAY 17 dB 1.8 GHz
19014606	OTTZ-4-20	OUTDOOR TAP TECHNETIX WIDE 4-WAY 20 dB 1.8 GHz
19014607	OTTZ-4-23	OUTDOOR TAP TECHNETIX WIDE 4-WAY 23 dB 1.8 GHz
19014608	OTTZ-4-26	OUTDOOR TAP TECHNETIX WIDE 4-WAY 26 dB 1.8 GHz
19014609	OTTZ-4-29	OUTDOOR TAP TECHNETIX WIDE 4-WAY 29 dB 1.8 GHz
19014610	OTTZ-8-11T	OUTDOOR TAP TECHNETIX WIDE 8-WAY 11 dB 1.8 GHz TERM
19014611	OTTZ-8-14	OUTDOOR TAP TECHNETIX WIDE 8-WAY 14 dB 1.8 GHz
19014612	OTTZ-8-17	OUTDOOR TAP TECHNETIX WIDE 8 WAY 17 dB 1.8 GHz
19014613	OTTZ-8-20	OUTDOOR TAP TECHNETIX WIDE 8-WAY 20 dB 1.8 GHz
19014614	OTTZ-8-23	OUTDOOR TAP TECHNETIX WIDE 8-WAY 23 dB 1.8 GHz
19014615	OTTZ-8-26	OUTDOOR TAP TECHNETIX WIDE 8-WAY 26 dB 1.8 GHz
19014616	OTTZ-8-29	OUTDOOR TAP TECHNETIX WIDE 8-WAY 29 dB 1.8 GHz

Conditioning plug-ins

Item number	Item code	Description
19014812	TXPI-EQZ-02	TECHNETIX PLUG-IN EQ 2 dB 1.8 GHz FOR OTTZ
19014813	TXPI-EQZ-03	TECHNETIX PLUG-IN EQ 3 dB 1.8 GHz FOR OTTZ
19014814	TXPI-EQZ-04	TECHNETIX PLUG-IN EQ 4 dB 1.8 GHz FOR OTTZ
19014815	TXPI-EQZ-06	TECHNETIX PLUG-IN EQ 6 dB 1.8 GHz FOR OTTZ
19014816	TXPI-EQZ-08	TECHNETIX PLUG-IN EQ 8 dB 1.8 GHz FOR OTTZ
19014817	TXPI-EQZ-09	TECHNETIX PLUG-IN EQ 9 dB 1.8 GHz FOR OTTZ
19014818	TXPI-EQZ-10	TECHNETIX PLUG-IN EQ 10 dB 1.8 GHz FOR OTTZ
19014819	TXPI-EQZ-12	TECHNETIX PLUG-IN EQ 12 dB 1.8 GHz FOR OTTZ
19014820	TXPI-EQZ-14	TECHNETIX PLUG-IN EQ 14 dB 1.8 GHz FOR OTTZ
19014821	TXPI-EQZ-16	TECHNETIX PLUG-IN EQ 16 dB 1.8 GHz FOR OTTZ
19014822	TXPI-EQZ-18	TECHNETIX PLUG-IN EQ 18 dB 1.8 GHz FOR OTTZ
19014823	TXPI-EQZ-20	TECHNETIX PLUG-IN EQ 20 dB 1.8 GHz FOR OTTZ
19014824	TXPI-EQZ-22	TECHNETIX PLUG-IN EQ 22 dB 1.8 GHz FOR OTTZ
19014825	TXPI-CSZ-02	TECHNETIX PLUG-IN CS 2 dB 1.8 GHz FOR OTTZ
19014826	TXPI-CSZ-03	TECHNETIX PLUG-IN CS 3 dB 1.8 GHz FOR OTTZ
19014827	TXPI-CSZ-04	TECHNETIX PLUG-IN CS 4 dB 1.8 GHz FOR OTTZ
19014828	TXPI-CSZ-06	TECHNETIX PLUG-IN CS 6 dB 1.8 GHz FOR OTTZ
19014829	TXPI-CSZ-08	TECHNETIX PLUG-IN CS 8 dB 1.8 GHz FOR OTTZ
19014830	TXPI-CSZ-09	TECHNETIX PLUG-IN CS 9 dB 1.8 GHz FOR OTTZ
19014831	TXPI-CSZ-10	TECHNETIX PLUG-IN CS 10 dB 1.8 GHz FOR OTTZ
19014832	TXPI-CSZ-12	TECHNETIX PLUG-IN CS 12 dB 1.8 GHz FOR OTTZ
19014833	TXPI-CSZ-15	TECHNETIX PLUG-IN CS 15 dB 1.8 GHz FOR OTTZ
19014834	TXPI-CSZ-18	TECHNETIX PLUG-IN CS 18 dB 1.8 GHz FOR OTTZ
19014835	TXPI-CSZ-21	TECHNETIX PLUG-IN CS 21 dB 1.8 GHz FOR OTTZ

If you would like further information on the content of this user manual, please contact:

Maarten Markhorst
Director of Connected Home Products
maarten.markhorst@technetix.com

© Copyright 2023 Technetix Group Limited. All rights reserved.

This document is for information only. Features and specifications are subject to change without notice. Technetix, the Technetix logo and certain other marks and logos are trade marks or registered trade marks of Technetix Group Limited in the UK and certain other countries. Other brand and company names are trade marks of their respective owners. Technetix protects its technology and designs by registering patents, trade marks and designs in Europe and certain other countries.