

XQT-OL5



- **Three output multimedia push-on**
- **Radio / TV/STB / data**
- **Ingress Safe™ - unique passive ingress reduction technology**
- **Modem Safe™ surge protection and intermodulation reduction solution**
- **Self-install**
- **Frequency range from 5 MHz to 1000 MHz**
- **Complies with EN Class A screening requirements**
- **Interchangeable/reversible input plate**
- **Robust silver plated zinc die-cast housing**



Overview

The XQT-OL5 is a push-on diplex filter that converts existing wall outlets into multimedia connections, enabling high speed data services and trouble-free use of analogue and digital radio and TV channels. The XQT-OL5's reversible input adapter plate allows the unit to be mounted in two different ways - with the output connectors facing either downwards or upwards. This enables the unit to be used with wall outlets that have been mounted upside down or that are mounted so close to the floor that cables cannot be connected from below the unit. The XQT-OL5's internal circuitry connects the TV port to the return path, allowing a set-top box to be connected to the TV port. As a self-install solution, the XQT-OL5 is ideal for operators rolling out interactive services on their networks.

Ingress Safe

Our patented Ingress Safe technology uses a phase cancellation technique to considerably reduce ingress created within the home. It has no adverse effect on the CATV spectrum and is transparent to the forward and reverse path signals.

- Significantly reduces noise on CATV networks, improving network performance
- Field tests show Ingress Safe units in the distribution network can deliver improvement in the carrier to noise ratio that averages from between 3 dB and 12 dB, depending on the network topology
- Prevents or delays the need to deploy technicians to rectify faults caused by the cumulative effects of ingress on network performance and customer service.

Modem Safe

Modem Safe is a highly effective surge protection solution for sensitive network and in-home CPE. Based on passive circuits, the technology does not rely on discharge tubes, extending the lifespan of the solution.

- Blocks high and low voltage pulses and unwanted DC voltages
- Prevents internal ferrites within the product from becoming magnetised (avoiding deterioration in the performance of CPE)
- Drives fewer reported faults
- Improves customer service
- Reduces truck rolls

Specifications

		MHz	Min	Typ	Max
Insertion loss (dB)	Input to STB/TV	5 - 10		3.6	4.3
		10 - 470		3.3	4.1
		470 - 862		3.5	4.3
		862 - 1000		3.7	4.8
	Input to data	5 - 10		4.0	4.7
		10 - 470		3.6	4.5
		470 - 862		3.8	4.7
		862 - 1000		4.0	5.0
	Input to radio	5 - 65	30.0	40.0	
		85 - 140		1.2	1.8
165 - 1000			35.0		
Return loss (dB, min)	Input, data and STB/TV	5 - 10		18.0	
		10 - 40		20.0	
		40 - 862 ¹		22.0	
		862 - 1000		16.0	
	Radio input/output	85 - 140		12.0	
	Isolation (dB, min)	Data - TV/STB	5 - 10		22.0
10 - 65				30.0	
65 - 1000 ¹				30.0	
Radio - data and STB/TV		85 - 140		40.0	
Screening efficiency (dB, typ). Minimum exceeds Class A ²		5 - 300		95.0	
		300-470		90.0	
		470 -1000		85.0	
Intermodulation p+q (dBc, min) ³			-105 dBc		
Ingress Safe	Out		Data port		
Surge Class conformance ⁴	All ports		1 kV 1.2/50µs		
Connectors	Radio/TV/STB		IEC-male ⁴		
	Data/TV/radio		IEC-female ^{4,5}		
	Data		F-female ^{6,7}		
	F-connector torque		10 Nm		
Material	Housing		Silver plated zinc die-cast		
Impedance (Ohm, typ)			75		
Dimensions (mm)	L x H x D				
Equipment approval	CE				

Remarks

- Where frequency is above 40 MHz, deduct 1.5 dB/Octave (return loss is always better than 16 dB min)
 - According to EN 50083-2 2006
 - Two carriers (60 and 65 MHz), out to out, at 120 dBmV/60 dBmV, after 10 pulse 25 V (1,2 mS rise time/50 mS duration) at all ports.
Two carriers (60 and 65 MHz), out to out, at 120 dBmV / 60 dBmV, after 1 pulse 1 kV combination wave (1,2 mS rise time/50 mS duration) at Input
 - According to IEC 60169-2 1965
 - IEC female connector: Inner pin with re-enforcement ring. BeCu outer spring.
 - F-female connector insert: BeCu (beryllium copper) C-strap (silver plated)
 - ANSI/SCTE-02 compliant
- Measurements taken at room temperature

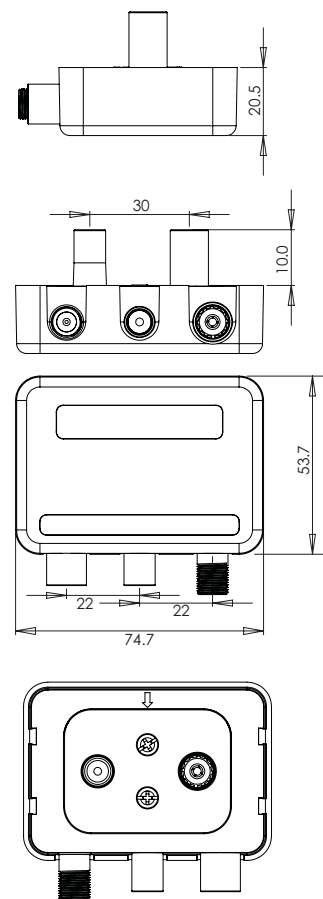

Ordering information

Item Name	Article number
XQT-OL5	19002752